

Safety Sentry™ Electronic Breakaway Switch

P-616
819-0454

Installation Instructions

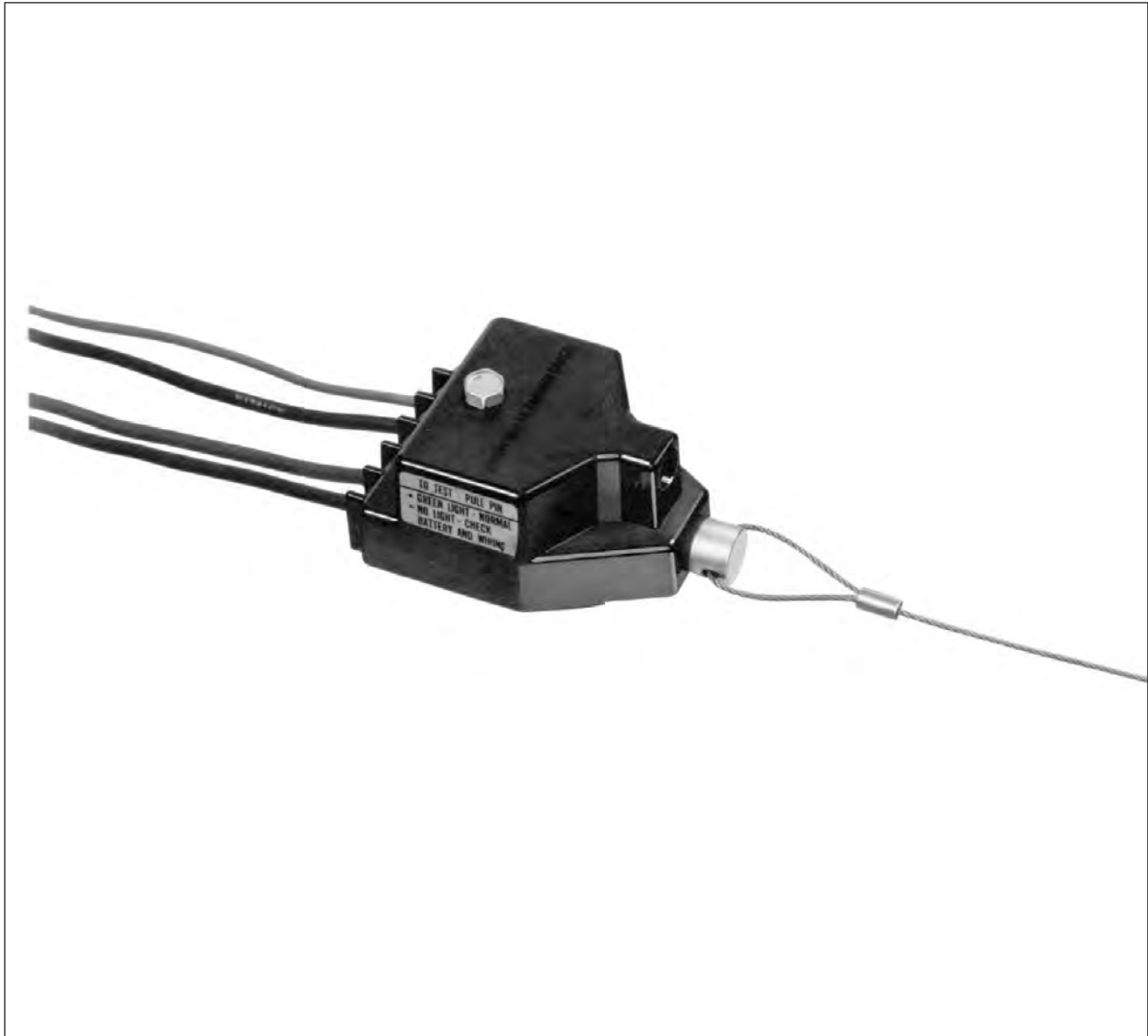

An Altra Industrial Motion Company



Parts List

Mounting hardware included with the Safety Sentry Breakaway Switch kit:

| Qty | Part |
|-----|------------------------------|
| 1 | Chain/lanyard with snap hook |
| 1 | 2-1/2" Bolt |
| 1 | 1-5/8" Sleeve |
| 2 | Eyebolts |
| 5 | Lockwashers |
| 5 | Nuts |

⚠ WARNING Failure to follow these instructions may result in product damage, equipment damage, and fatal injury to personnel.

Introduction

The main purpose of any trailer breakaway switch is to automatically engage the electric trailer brakes should the trailer become detached from the towing vehicle. In addition to this basic function, your Safety Sentry Breakaway Switch will:

1. Test the battery under load for approximately 10 volts minimum.
2. Illuminate its green light to indicate that the trailer battery and breakaway switch are operating properly.

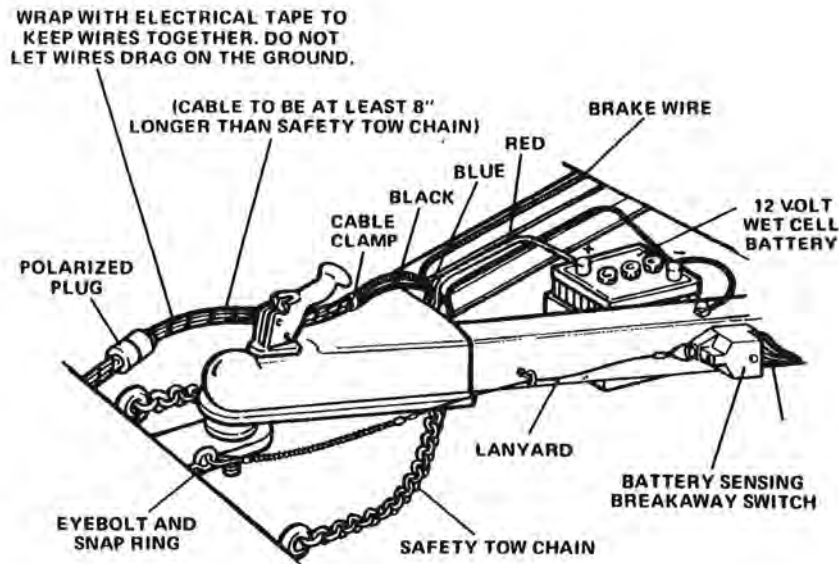

Figure 1 - Typical Layout

Mounting

Note the general layout in Figure 1 as you proceed through the mounting instructions. Refer to the parts list, page 2.

1. Drill a 9/32-inch hole for an eyebolt in a convenient structural member on your towing vehicle chassis near the hitch (not on the hitch assembly).

Mount the eyebolt, with the eyebolt pointing toward the breakaway switch, using two 1/4-inch nuts with lockwashers. Tighten securely. See Figure 2.

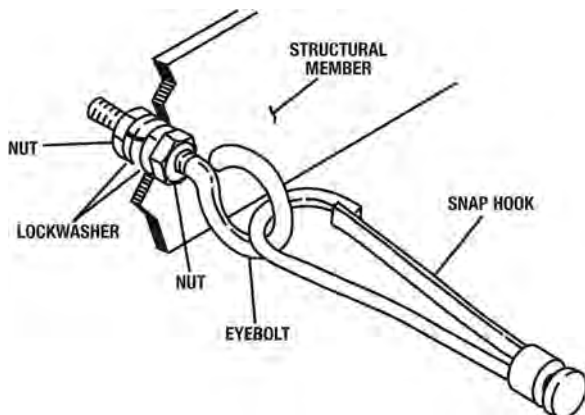

Figure 2
 Towing Vehicle Eyebolt Mounting

2. Position the breakaway switch on a horizontal or vertical surface of the trailer tongue or A-frame. The pin in the switch must point towards the towing vehicle.

The switch must be positioned far enough forward so the lanyard will reach the towing vehicle.

It must also be set back far enough to allow an eyebolt to be mounted to the tongue in front of the switch.

3. Drill a 9/32-inch hole through the tongue for mounting the switch.

Insert the furnished metal sleeve into the mounting hole in the switch. The sleeve allows the switch to pivot so the lanyard stays aligned with the towing vehicle.

Bolt the switch to the tongue using the bolt, nut, and lockwasher provided.

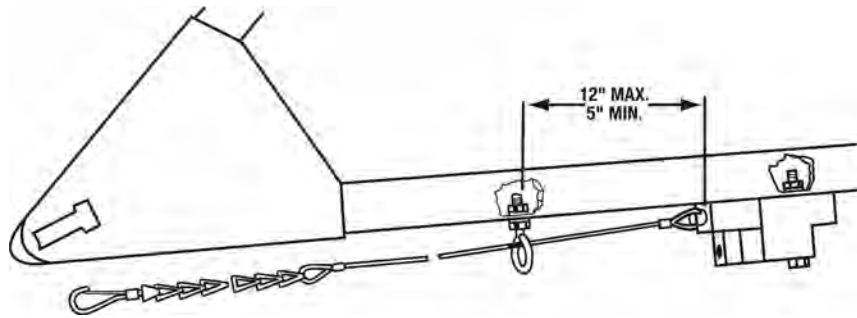

Figure 3 - Trailer Tongue Eyebolt Mounting

4. Refer to Figure 3 for correct location for mounting the second eyebolt.

Drill a 9/32-inch hole for the eyebolt. Secure with two 1/4-inch nuts and two lockwashers. This eyebolt is necessary so that the pin will be pulled straight out from the breakaway switch if the trailer should become disconnected.

5. Insert the breakaway switch disengagement pin into the breakaway switch.
6. Disconnect the snap hook (it is not permanently attached) from the chain end of the lanyard assembly. Save the hook and its attachment clip.
7. Thread the lanyard, chain end first, through the eyebolt mounted on the trailer tongue.
8. Determine the correct length for the lanyard. The lanyard is the correct length if the following conditions are satisfied:

Condition 1: If trailer should become disconnected, the lanyard must become taut and pull the pin out of the breakaway switch before the trailer safety chains become taut.

Condition 2: If the trailer should become disconnected, the lanyard must become taut and pull the pin out of the breakaway switch

before the towing vehicle-to-trailer electrical wiring becomes taut. Making the electrical wires longer than the safety chains is a convenient way to accomplish this.

Condition 3: During normal towing operation, the lanyard must NOT become taut enough to pull the pin out of the breakaway switch when turning a corner.

Condition 4: During normal towing operation, either straight or while turning corners, no chains or wiring should be allowed to drag on the ground.

Adjust the lanyard to the right length by removing the individual chain links.

The lanyard, if installed correctly, now extends from the switch, with the pin inserted into the switch, through the eyebolt on the trailer tongue, and attaches to the eyebolt on the towing vehicle.

9. Leaving the lanyard threaded through the eyebolt on the trailer tongue, secure the snap hook to the end chain link. Use pliers to close the snap hook attachment clip completely around the end of the snap hook.
10. Fasten snap hook to the towing vehicle eyebolt.

Electrical Connection

Recommended Parts List for Customer Wiring:

| Item | Qty | Description |
|------|-----|----------------------------------------------------------------------------------------------|
| 1. | 6' | No. 12 AWG insulated wire (stranded) blue |
| 2. | 6' | No. 12 AWG insulated wire (stranded) black |
| 3. | 6' | No. 12 AWG insulated wire (stranded) white |
| 4. | 6' | No. 12 AWG insulated wire (stranded) red |
| 5. | 2 | 1/4-inch bolts, length suitable for the type of trailer tongue used |
| 6. | 2 | 1/4-inch nuts |
| 7. | 4 | washers for 1/4-inch bolt |
| 8. | 2 | lockwashers for 1/4-inch bolt |
| 9. | 1 | roll of electrical tape |
| 10. | 3 | wire nuts or insulated line connectors (binding screw type) for three No. 12 AWG wires |
| 11. | 1 | socket and plug connector with a minimum of three poles capable of accepting No. 12 AWG wire |
| 12. | 1 | 12 volt wet cell battery (100 amp-hour max.) |

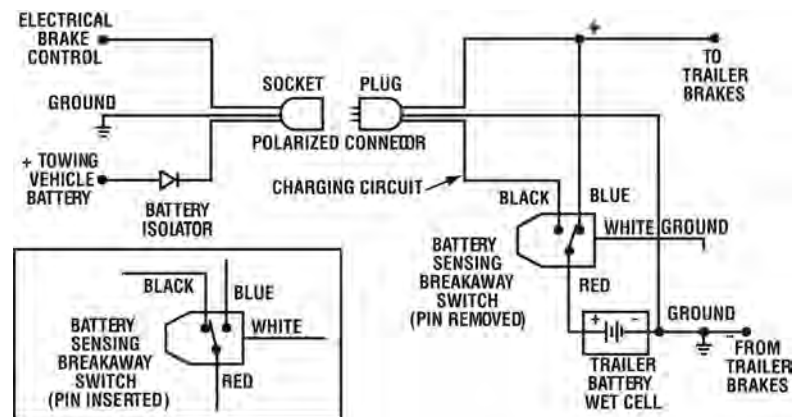

Figure 4 - Wiring Diagram

Refer to the wiring diagram shown in Figure 4 as you follow the electrical connection instructions below. Plan ahead by starting with long wires. All wires must be a least No. 12 AWG and insulated. The final length of the wires from the trailer, including the connector, should be longer than the safety chains.

(Note: Refer to Mounting, Item 8, Condition 2).

The trailer battery must be 12 volts and have adequate capacity to meet all legal requirements of the state in which the trailer will be towed.

Use a wet cell storage battery with a maximum rated capacity of 100 amp-hours.

Solder connections are preferable for attaching two wires together. If crimp-type connectors are used, make sure they are crimped tightly. All such connections should be taped with electrical tape to prevent corrosion and short circuiting.

Your breakaway switch has four wires: white, blue, black, and red. They should be connected as follows:

1. Ground – White Wire

Attach the white wire to the trailer frame adjacent to the switch using a 1/4-inch bolt, nut, two washers, and one lockwasher. Be sure the frame area is bare metal and free of rust. (See Figure 5)

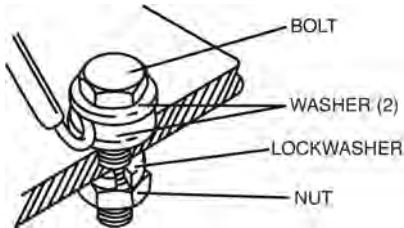

Figure 5 - Ground Connections

The wire must be long enough for the switch to swivel freely after the connection to the trailer frame has been made. Make sure the final connection is tight.

Connect the trailer battery ground (-) to the trailer frame, also using 1/4-inch bolt, nut, two washers, and one lockwasher as shown in Figure 5.

Make sure the final connection is tight. (**Note:** The white wire from the switch and the battery ground terminal may be connected to one common ground on the trailer frame if convenient.)

A ground wire should be run from the towing vehicle battery (-) to the socket at the rear of the vehicle. From the socket, the ground wire should be connected to the trailer frame.

(There should now be a total of 3 ground connections: the breakaway switch white wire to the trailer frame; the ground side of the trailer battery to the trailer frame; the ground side of the towing vehicle battery, through the socket at the rear of the vehicle, to the trailer frame.)

2. Brakes – Blue Wire

Connect the blue wire to the positive (+) wire running to the trailer brakes. Be careful not to connect to the ground (-) wire leading from the brakes.

3. Trailer Battery Charging – Black Wire

Warner Electric recommends that a charging circuit be used to maintain the trailer battery in a fully-charged condition.

- a. If a charging circuit is used, it must be connected through the Safety Sentry switch using the black wire as shown in Figure 4.

Connect the black wire from the switch, through the polarized connector, to the output side of the battery isolator. If a battery isolator is not used, connect the wire directly to the towing vehicle battery (+) terminal.

⚠ WARNING Failure to connect the charging circuit through the switch will result in incorrect operation of the switch.

- b. If a charging circuit is not used, cut off the black wire from the Safety Sentry close to the switch's plastic housing. Insulate the exposed end of the wire with a recognized electrical insulating tape or equivalent. This will prevent the exposed lead from grounding.

⚠ WARNING Failure to cut off and insulate the black wire when no charging circuit is used could cause an electrical short circuit. This may deplete the trailer battery and destroy the Safety Sentry, completely immobilizing the breakaway system.

4. Trailer Battery – Red Wire

Connect the red wire directly to the trailer battery (+) terminal using an appropriate battery connector.

Operation

Your Safety Sentry Breakaway Switch should now be ready for use. Always test the system before using it to assure that it is in proper working condition.

Use the following procedure to test the brake system:

1. Put the towing vehicle in "Park". Set the emergency brake if the vehicle has manual transmission.
2. Couple the plug and socket together.
3. Pull the disengagement pin from the switch. The green light on the switch will illuminate for at least 10 seconds if the system is connected and the battery is functioning properly.
4. If the green light does not illuminate, use the following procedure to check the system and locate the cause of the problem:
 - a. Check your wiring to ensure all connections have been made properly. Refer to Figure 4. Check all connections to be sure they are tight. Check ground connections to be sure they are attached to rust-free areas of the trailer frame. They must be connected to bare metal surfaces.

Correct any errors which have been made. If the green light does not illuminate, proceed with the next step.

- b. Use a voltmeter to check the trailer battery for proper output. The battery must supply at least 10 volts, with the switch pin pulled (trailer brakes on), for the green light to illuminate.

If the voltage is low, the battery should be charged to a minimum of 10 volts and checked again with the pin pulled before the trailer is towed.

The battery will be charged directly from the towing vehicle while the engine is running. To accomplish this the pin must be inserted in the switch.

If the battery does not charge to 10 volts, it must be replaced.

The green light should now illuminate, or the trailer brakes must be checked.

- c. Check the trailer brake wiring. All brake magnets should be connected with good quality connectors and taped to avoid a possible short circuit.
 - d. The green light should now illuminate, or the Safety Sentry should be replaced.
 - e. As a final check, pull the disengagement pin on the Safety Sentry and try to pull the trailer forward with the towing vehicle. If the trailer brakes are engaged, it will be difficult for the towing vehicle to move the trailer.

⚠CAUTION If the trailer and towing vehicle are connected while parked, prolonged use of the trailer battery for lights or other purposes will also drain the towing vehicle battery. The problem can be avoided by disconnecting the plug from the socket.

DO NOT USE AS A PARKING BRAKE (pin removed). Prolonged activation will discharge the battery and cause the brakes to release.

Warranty

Warner Electric LLC warrants that it will repair or replace (whichever it deems advisable) any product manufactured and sold by it which proves to be defective in material or workmanship within a period of one (1) year from the date of original purchase for consumer, commercial or industrial use.

This warranty extends only to the original purchaser and is not transferable or assignable without Warner Electric LLC's prior consent.

Warranty service can be obtained in the U.S.A. by returning any defective product, transportation charges prepaid, to the appropriate Warner Electric LLC factory. Additional warranty information may be obtained by writing the Customer Satisfaction Department, Warner Electric LLC, 449 Gardner Street, South Beloit, Illinois 61080, or by calling 815-389-3771.

A purchase receipt or other proof of original purchase will be required before warranty service is rendered. If found defective under the terms of this warranty, repair or replacement will be made, without charge, together with a refund for transportation costs. If found not to be defective, you will be notified and, with your consent, the item will be repaired or replaced and returned to you at your expense.

This warranty covers normal use and does not cover damage or defect which results from alteration, accident, neglect, or improper installation, operation, or maintenance.

Some states do not allow limitation on how long an implied warranty lasts, so the above limitation may not apply to you.

Warner Electric LLC's obligation under this warranty is limited to the repair or replacement of the defective product and in no event shall Warner Electric LLC be liable for consequential, indirect, or incidental damages of any kind incurred by reason of the manufacture, sale or use of any defective product. Warner Electric LLC neither assumes nor authorizes any other person to give any other warranty or to assume any other obligation or liability on its behalf.

WITH RESPECT TO CONSUMER USE OF THE PRODUCT, ANY IMPLIED WARRANTIES WHICH THE CONSUMER MAY HAVE ARE LIMITED IN DURATION TO ONE YEAR FROM THE DATE OF ORIGINAL CONSUMER PURCHASE. WITH RESPECT TO COMMERCIAL AND INDUSTRIAL USES OF THE PRODUCT, THE FOREGOING WARRANTY IS IN LIEU OF AND EXCLUDES ALL OTHER WARRANTIES, WHETHER EXPRESSED OR IMPLIED BY OPERATION OF LAW OR OTHERWISE, INCLUDING, BUT NOT LIMITED TO, ANY IMPLIED WARRANTIES OF MERCHANTABILITY OR FITNESS.

Some states do not allow the exclusion or limitation of incidental or consequential damages, so the above limitation or exclusion may not apply to you. This warranty gives you specific legal rights and you may also have other rights which vary from state to state.

Changes in Dimensions and Specifications

All dimensions and specifications shown in Warner Electric catalogs are subject to change without notice. Weights do not include weight of boxing for shipment. Certified prints will be furnished without charge on request to Warner Electric.



Warner Electric LLC
449 Gardner Street • South Beloit, IL 61080
815-389-3771 • Fax: 815-389-2582
www.warnerelectric.com
An Altra Industrial Motion Company